

TL5G Universal Compressor R134a 220-240V 50Hz

Data Sheet (Replaces CG.42.C1.02)

General

Compressor	TL5G
Code number	102G4550

Application

Application		LBP/HBP
Evaporating temperature range	°C	-30 to 15
Voltage range	V/Hz	LBP: 187 - 254 /50
		LBP: 198 - 254 /60
		HBP: 198 - 254 /50
Motor type		RSIR/CSIR
Max. ambient temperature	°C	43
Comp. cooling at ambient temp.	32°C	LBP: S
		HBP: F ₂
	38°C	LBP: S
		HBP: F ₂
43°C	LBP: S	
	HBP: F ₂	

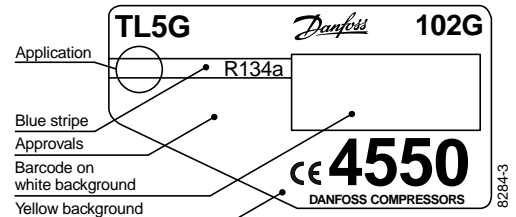

- S = Static cooling normally sufficient
- O = Oil cooling
- F₁ = Fan cooling 1.5 m/s
(compressor compartment temperature equal to ambient temperature)
- F₂ = Fan cooling 3.0 m/s necessary

Design

Displacement	cm ³	5.08
Oil quantity	cm ³	280
Maximum refrigerant charge	g	400
Free gas vol. in compressor	cm ³	1690
Weight without electrical equipment	kg	7.5

Motor

Motor size	watt	140
LRA (rated after 4 sec. UL984) LST/HST	A	5.4/5.7
Cut-in current LST/HST	A	9.7/5.7
Resistance, main and start winding (25°C)	Ω	14.5/14.8
Approvals		EN 60335-2-34

Dimensions

Height	mm	A	173
		B	169
Suction connector	location/I.D. mm	C	6.2 ±0.09
Process connector	location/I.D. mm	D	6.2 ±0.09
Discharge connector	location/I.D. mm	E	5.0 +0.12/+0.20
Compressors on a pallet	pcs.		125

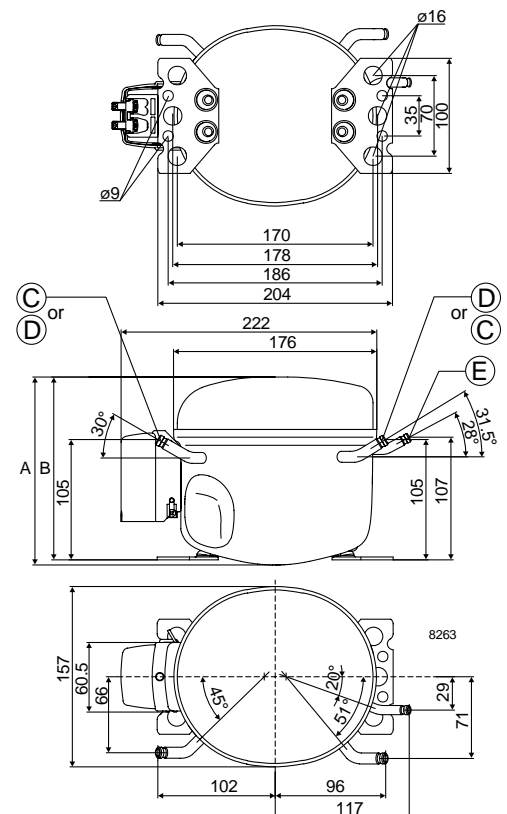

Capacity (EN 12900/CECOMAF)

watt

Evap. temp in °C	-30	-25	-23.3	-20	-15	-10	-5	0	5	7.2	10	15
TL5G, 50Hz	55.6	79.0	87.9	107	139	178	224	278	341	372	414	497
TL5G, 60Hz	64.7	91.5	102	123	162	207						

Capacity (ASHRAE)

watt

Evap. temp in °C	-30	-25	-23.3	-20	-15	-10	-5	0	5	7.2	10	15
TL5G, 50Hz	68.6	97.5	108	132	172	220	277	345	423	461	514	619
TL5G, 60Hz	79.8	113	125	152	200	256						

Power consumption

watt

Evap. temp in °C	-30	-25	-23.3	-20	-15	-10	-5	0	5	7.2	10	15
TL5G, 50Hz	84.8	100	105	116	132	149	167	186	205	213	224	245
TL5G, 60Hz	88.7	105.7	112.1	125	147	170						

Current consumption

A

Evap. temp in °C	-30	-25	-23.3	-20	-15	-10	-5	0	5	7.2	10	15
TL5G, 50Hz	0.95	0.98	0.99	1.01	1.05	1.09	1.15	1.21	1.28	1.32	1.36	1.45
TL5G, 60Hz	0.83	0.88	0.90	0.94	1.01	1.08						

COP (EN 12900/CECOMAF)

W/W

Evap. temp in °C	-30	-25	-23.3	-20	-15	-10	-5	0	5	7.2	10	15
TL5G, 50Hz	0.66	0.79	0.83	0.92	1.05	1.19	1.34	1.50	1.67	1.74	1.84	2.03
TL5G, 60Hz	0.73	0.87	0.91	0.99	1.10	1.22						

COP (ASHRAE)

W/W

Evap. temp in °C	-30	-25	-23.3	-20	-15	-10	-5	0	5	7.2	10	15
TL5G, 50Hz	0.81	0.97	1.03	1.14	1.30	1.47	1.66	1.86	2.07	2.16	2.29	2.53
TL5G, 60Hz	0.90	1.07	1.12	1.22	1.36	1.51						

Test conditions	EN 12900/CECOMAF	ASHRAE
Condensing temperature	55°C	55°C
Ambient and suction gas temp.	32°C	32°C
Liquid temperature	55°C	32°C
50Hz: Static cooling, 220V		
60Hz: Static cooling, 220V		

Accessories

Devices	Fig.	TL5G
PTC starting device	6.3 mm spades	103N0011
	4.8 mm spades	103N0018
Starting relay	a2	117U6000
Cover	b	103N2010
Starting capacitor 60 µF	c	117U5014
Cord relief	d	103N1010
Protection screen for PTC	g	103N0476
Mounting accessories		
Bolt joint for one compressor		118-1917
Bolt joint in quantities		118-1918
Snap-on in quantities		118-1919

